

**INSTYTUT TECHNIKI BUDOWLANEJ**  
PL 00-611 WARSZAWA  
ul. FILTROWA 1  
tel.: (48 22) 825-04-71;  
(48 22) 825-76-55;  
fax: (48 22) 825-52-86;  
[www.itb.pl](http://www.itb.pl)

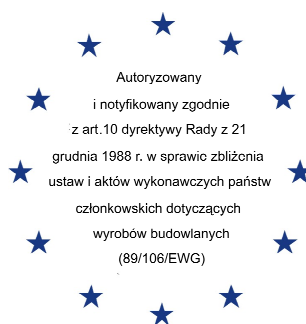

**Członek EOTA**

## European Technical Approval

**ETA-11/0126**

English language translation - the original version is in Polish language

### Nazwa handlowa

*Trade name*

**RAWL SafetyPlus**

*RAWL SafetyPlus*

### Właściciel aprobaty

*Holder of approval*

**RAWLPLUG LIMITED**

**21 Holborn Viaduct, London, EC1A 2DY  
United Kingdom**

### Rodzaj i przeznaczenie wyrobu

*Generic type and use  
of construction products*

**Kotwy rozporowe z kontrolowanym momentem dokręcenia o średnicach M8, M10, M12, M16 i M20 do wykonywania zamocowań w betonie niezarysowanym**

*Torque controlled expansion anchor of sizes M8, M10, M12, M16 and M20 for use in non-cracked concrete*

### Termin ważności

*Valid*

**od  
from  
do  
to**

**29. 12. 2011**

**29. 12. 2016**

### Zakład produkcyjny

*Manufacturing plant*

**1 – Zakład produkcyjny nr 1  
Manufacturing Plant no. 1**

**2 – Zakład produkcyjny nr 2  
Manufacturing Plant no. 2**

### Niniejsza Europejska Aprobata Techniczna zawiera

*This European Technical  
Approval contains*

**18 stron, w tym 11 Załączników**

*18 pages including 11 Annexes*



Europejska Organizacja ds. Aprobatach Technicznych

European Organisation for Technical Approvals

## I LEGAL BASES AND GENERAL CONDITIONS

1. This European Technical Approval is issued by Instytut Techniki Budowlanej in accordance with:
  - Council Directive 89/106/EEC of 21 December 1988 on the approximation of laws, regulations and administrative provisions of Member States relating to construction products<sup>1</sup>, amended by the Council Directive 93/68/EEC of 22 July 1993<sup>2</sup>;
  - ustawa z dnia 16 kwietnia 2004 r. o wyrobach budowlanych (law on construction products from 16<sup>th</sup> April 2004)<sup>3</sup>;
  - rozporządzenie Ministra Infrastruktury z dnia 14 października 2004 r. w sprawie europejskich aprobat technicznych oraz polskich jednostek organizacyjnych upoważnionych do ich wydawania (regulation of Ministry of Infrastructure of 14<sup>th</sup> October 2004 on the European Technical Approvals and Polish bodies entitled to issue them)<sup>4</sup>;
  - Common Procedural Rules for Requesting, Preparing and the Granting of European Technical Approvals set out in the Annex of Commission Decision 94/23/EC<sup>5</sup>;
  - Guideline for European Technical Approval of „*Metal anchors for use in concrete – Part 2: Torque controlled expansion anchors*”, ETAG 001-02.
2. Instytut Techniki Budowlanej is authorized to check whether the provisions of this European Technical Approval are met. Checking may take place in the manufacturing plant. Nevertheless, the responsibility for the conformity of the products to the European Technical Approval and for their fitness for the intended use remains with the holder of the European Technical Approval.
3. This European Technical Approval is not to be transferred to manufacturers or agents of manufacturers other than those indicated on page 1, or manufacturing plants other than those indicated on page 1 of this European Technical Approval.
4. This European Technical Approval may be withdrawn by Instytut Techniki Budowlanej, in particular after information by the Commission on the basis of Article 5 (1) of Council Directive 89/106/EEC.
5. Reproduction of this European Technical Approval including transmission by electronic means shall be in full. However, partial reproduction can be made with the written consent of Instytut Techniki Budowlanej. In this case partial reproduction has to be designated as such. Texts and drawings of advertising brochures shall not contradict or misuse the European Technical Approval.
6. The European Technical Approval is issued by the approval body in its official language. This version corresponds to the version circulated within EOTA. Translations into other languages have to be designated as such.

---

<sup>1</sup> Official Journal of the European Communities № L 40, 11.02.1989, p. 12

<sup>2</sup> Official Journal of the European Communities № L 220, 30.08.1993, p. 1

<sup>3</sup> Official Journal of Polish Republic № 92/2004, pos. 881

<sup>4</sup> Official Journal of Polish Republic № 237/2004, pos. 2375

<sup>5</sup> Official Journal of the European Communities № L 17, 20.01.1994, p. 34

## **II SPECIFIC CONDITIONS OF THE EUROPEAN TECHNICAL APPROVAL**

### **1 Definition of the product and intended use**

#### **1.1 Definition of the product**

The RAWL SafetyPlus anchors type R-SPL, R-SPL-C and R-SPL-BP in the sizes of M8 to M20 (R-SPL in the sizes M8 to M20, R-SPL-C in the sizes M8 to M16 and R-SPL-BP in the sizes M8 to M20) are an anchors made of galvanized steel which is placed into a drill hole and anchored by torque-controlled expansion.

An illustration of the product and intended use are given in Annexes 1, 2 and 3.

#### **1.2 Intended use**

The anchor is intended to be used for anchorages for which requirements for mechanical resistance and stability and safety in use in the sense of the Essential Requirements 1 and 4 of Council Directive 89/106/EEC shall be fulfilled and failure of anchorages made with these products would cause risk to human life and/or lead to considerable economic consequences. The anchor is to be used only for anchorages subject to static or quasi-static loading in reinforced or unreinforced normal weight concrete of strength classes C20/25 at minimum and C50/60 at maximum according to EN 206.

The anchor may be anchored in non-cracked concrete only.

The anchor may only be used in structures subject to dry internal conditions.

The provisions made in this European Technical Approval are based on an assumed working life of the anchor of 50 years. The indications given on the working life cannot be interpreted as a guarantee given by the producer or Approval Body, but are to be regarded only as a means for choosing the right products in relation to the expected economically reasonable working life of the works.

### **2 Characteristics of the product and methods of verification**

#### **2.1 Characteristics of the product**

The anchors correspond to the drawings and provisions given in Annexes 1 to 9. The characteristic material values, dimensions and tolerances of the anchor not given in Annexes 7 to 9 shall correspond to the respective values laid down in the technical documentation<sup>6</sup> of this European Technical Approval.

The characteristic values for the design of the anchorages are given in Annexes 10 and 11.

Each anchor is marked with identifying mark of the manufacturer, the anchor identity, the drill hole diameter and the anchor size according to Annex 1.

The anchor shall only be packaged and supplied as a complete unit.

---

<sup>6</sup> The technical documentation of this European Technical Approval is deposited at the Instytut Techniki Budowlanej and, as far as relevant for the tasks of the approved body involved in the attestation of conformity procedure, is handed over to the approved bodies.

## **2.2 Methods of verification**

The assessment of fitness of the anchor for the intended use in relation to the requirements for mechanical resistance and stability and safety in use in the sense of the Essential Requirement 1 and 4 has been made in accordance with the *Guideline for European Technical Approval of „Metal Anchors for Use in Concrete”, ETAG-001-02, Part 1: “Anchors in general” and Part 2: “Torque-controlled expansion anchors”*, on the basis of Option 7.

In addition to the specific clauses relating to dangerous substances contained in this ETA, there may be other requirements applicable to the products falling within its scope (e.g. transposed European legislation and national laws, regulations and administrative provisions). In order to meet the provisions of the Construction Products Directive, these requirements need also to be complied with, when and where they apply.

## **3 Evaluation and attestation of conformity and CE-marking**

### **3.1 Attestation of conformity system**

According to the Decision 96/582/EG of the European Commission<sup>7</sup> the system 2 (i) (referred to as system 1) of attestation of conformity applies.

This system of attestation of conformity is defined as follows:

System 1: Certification of the conformity of the product by an approved certification body on the basis of:

(a) Tasks for the manufacturer:

- (1) factory production control,
- (2) further testing of samples taken at the factory by the manufacturer in accordance with a prescribed test plan,

(b) Tasks for the approved body:

- (3) initial type-testing of the product,
- (4) initial inspection of factory and of factory production control,
- (5) continuous surveillance, assessment and approval of factory production control.

### **3.2 Responsibilities**

#### **3.2.1 Tasks for the manufacturer**

##### **3.2.1.1 Factory production control**

The manufacturer shall exercise permanent internal control of production. All the elements, requirements and provisions adopted by the manufacturer shall be documented in a systematic manner in the form of written policies and procedures, including records of results performed. This production control system shall insure that the product is in conformity with this European Technical Approval.

---

<sup>7</sup> Official Journal of the European Communities L 254 of 08.10.1996

The manufacturer may only use raw materials stated in the technical documentation of this European Technical Approval.

The factory production control shall be in accordance with the control plan<sup>8</sup> which is part of the technical documentation of this European Technical Approval. The control plan is laid down in the context of the factory production control system operated by the manufacturer and deposited at Instytut Techniki Budowlanej.

The results of factory production control shall be recorded and evaluated in accordance with the provisions of the control plan.

#### 3.2.1.2 Other tasks of manufacturer

The manufacturer shall, on the basis of a contract, involve a body which is approved for the tasks referred to in section 3.1 in the field of anchors in order to undertake the actions laid down in section 3.2.2. For this purpose, the control plan referred to in section 3.2.1.1 and 3.2.2 shall be handed over by the manufacturer to the approved body involved.

The manufacturer shall make a declaration of conformity, stating that the construction product is in conformity with the provisions of this European Technical Approval.

### 3.2.2 Tasks for the approved bodies

The approved body shall perform the:

- initial type-testing of the product,
- initial inspection of factory and of factory production control,
- continuous surveillance, assessment and approval of factory production control,

in accordance with the provisions laid down in the control plan.

The approved body shall retain the essential points of its actions referred to above and state the results obtained and conclusions drawn in a written report.

The approved certification body involved by the manufacturer shall issue an EC certificate of conformity of the product stating the conformity with the provision of this European Technical Approval.

In cases where the provisions of the European Technical Approval and its control plan are no longer fulfilled the certification body shall withdraw the certificate of conformity and inform Instytut Techniki Budowlanej without delay.

### 3.3 CE-marking

The CE-marking shall be affixed on each packaging of the anchor. The letters „CE” shall be accompanied by the following additional information:

- the identification number of the approved certification body,
- the name or identification mark of the producer (legal entity responsible for the manufacture) and address of the producer,
- the last two digits of the year in which the CE-marking was affixed,

---

<sup>8</sup> The control plan is a confidential part of the European Technical Approval and may be handed over only to the approved body involved in the procedure of attestation of conformity.

- the number of the EC certificate of conformity for the product,
- the number of the European Technical Approval,
- the number of the guideline for European Technical Approval,
- use category (ETAG 001-1 Option 7),
- size.

## **4 Assumptions under which the fitness of the product for the intended use was favorably assessed**

### **4.1 Manufacturing**

The European Technical Approval is issued for the product on the basis of agreed data/information, deposited at Instytut Techniki Budowlanej which identifies the product that has been assessed and judged. Changes to the product or production process, which could result in this deposited data/information being incorrect, should be notified to the Instytut Techniki Budowlanej before the changes are introduced. Instytut Techniki Budowlanej will decide whether or not such changes affect the ETA and consequently the validity of the CE marking on the basis of the ETA and if so whether further assessment or alterations to the ETA shall be necessary.

### **4.2 Design of anchorages**

The fitness of the anchor for the intended use is given under the following conditions:

- the anchorages are designed in accordance with the “Guideline for European Technical Approval ETAG-001 of *“Metal Anchors for Use in Concrete”, Annex C, Method A*”, under the responsibility of an engineer experienced in anchorages and concrete work,
- verifiable calculation notes and drawings are taking account of the loads to be transmitted,
- the position of the anchor is indicated on the design drawings (e.g. position of the anchor relative to reinforcement or to supports).

### **4.3 Installation of anchors**

The fitness for use of the anchor can only be assumed if the anchor is installed as follows:

- anchor installation carried out by appropriately qualified personnel and under the supervision of the person responsible for technical matters of the site,
- use of the anchor only as supplied by the manufacturer without exchanging any component of the anchor,
- anchor installation in accordance with the manufacturer's specifications and drawings and using the appropriate tools,
- checks before placing the anchor to ensure that the strength class of the concrete in which the anchor is to be placed is in the range given and is not lower than that to which the characteristic loads apply,
- check of concrete being well compacted, e.g. without significant voids,

- edge distances and spacings not less than the specified values without minus tolerances,
- positioning of the drill holes without damaging the reinforcement,
- in case of aborted hole: new drilling at a minimum distance away of twice the depth of the aborted hole or smaller distance if the aborted drill hole is filled with high strength mortar and if under shear or oblique tension load it is not in the direction of load application,
- cleaning of the hole of drilling dust,
- anchor installation such that the effective anchorage depth is in accordance with Annex 9,
- application of the torque moment given in Annex 9 using a calibrated torque wrench.

## **5 Responsibility of the manufacturer**

The manufacturer is responsible to ensure that the information on the specific conditions according to 1, 2 and 4 is given to those who are concerned. This information may be made by reproduction of the respective parts of the European Technical Approval. In addition all installation data shall be shown clearly on the package and/or on an enclosed instruction sheet, preferably using illustration(s).

The minimum data required are:

- diameter of drill bit,
- thread diameter,
- maximum thickness of the fixture,
- minimum effective anchorage depth,
- minimum hole depth,
- torque moment,
- information on the installation procedure, including cleaning of the hole, preferably by means of an illustration,
- reference to any special installation equipment needed,
- identification of the manufacturing batch.

All data shall be presented in a clear and explicit form.

On behalf of Instytut Techniki Budowlanej



Marek Kaproń  
Director of ITB

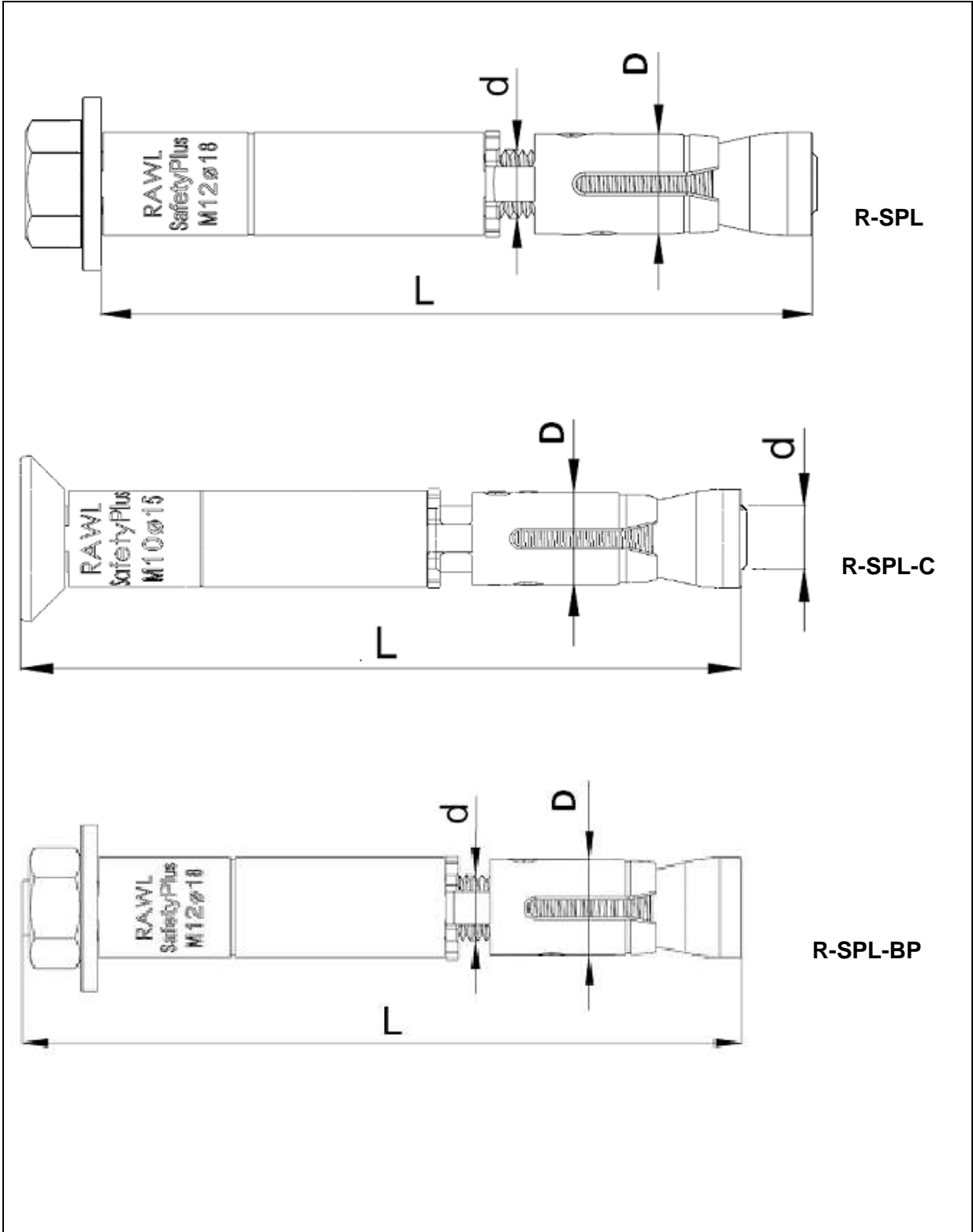

<b>RAWL SafetyPlus</b>	<b>Annex 1</b> of European Technical Approval ETA-11/0126
Product	



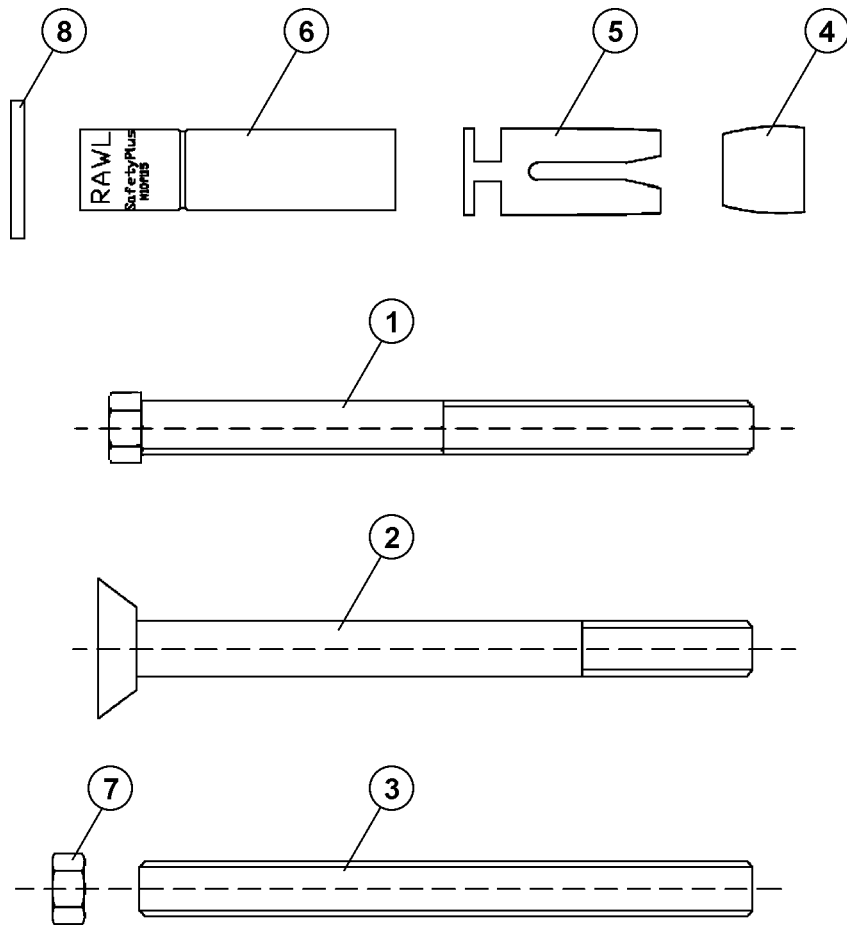

- 1 – hexagonal screw,
- 2 – countersunk screw,
- 3 – threaded bolt,
- 4 – conical nut,
- 5 – expansion sleeve,
- 6 – spacer sleeve,
- 7 – hexagonal nut,
- 8 – washer

**RAWL SafetyPlus**

Different parts of the anchor

**Annex 2**  
of European  
Technical Approval  
ETA-11/0126

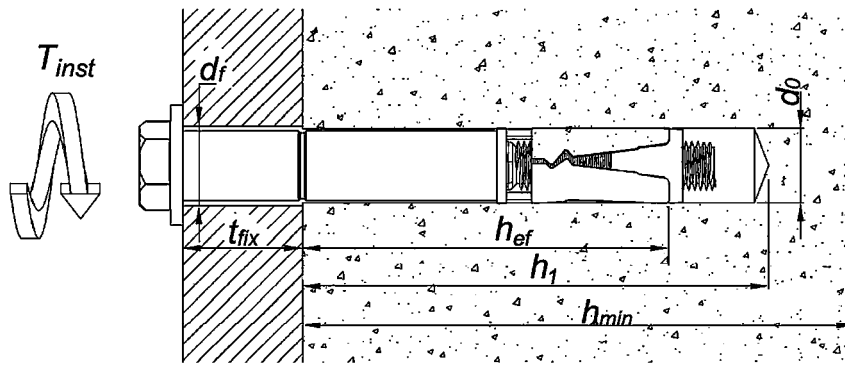

R-SPL

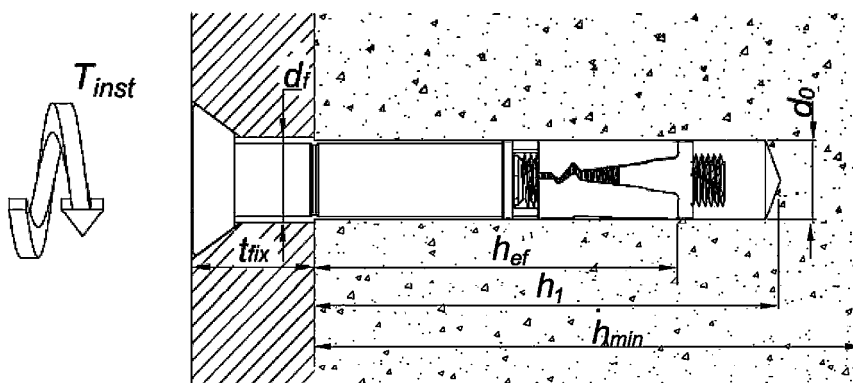

R-SPL-C

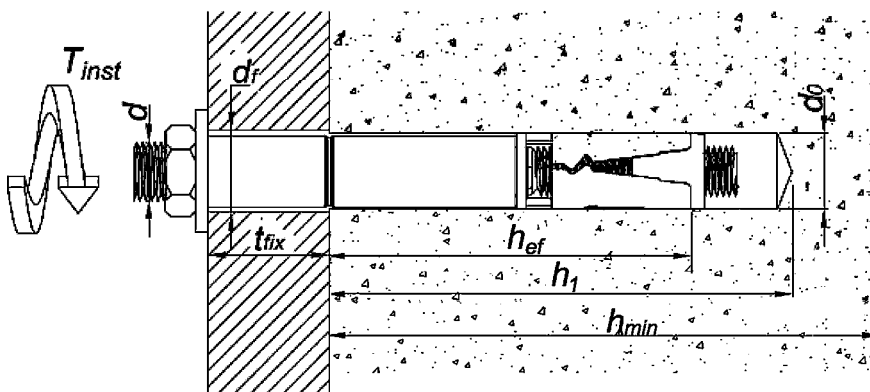

R-SPL-BP

**RAWL SafetyPlus**

Intended use

**Annex 3**  
 of European  
 Technical Approval  
 ETA-11/0126

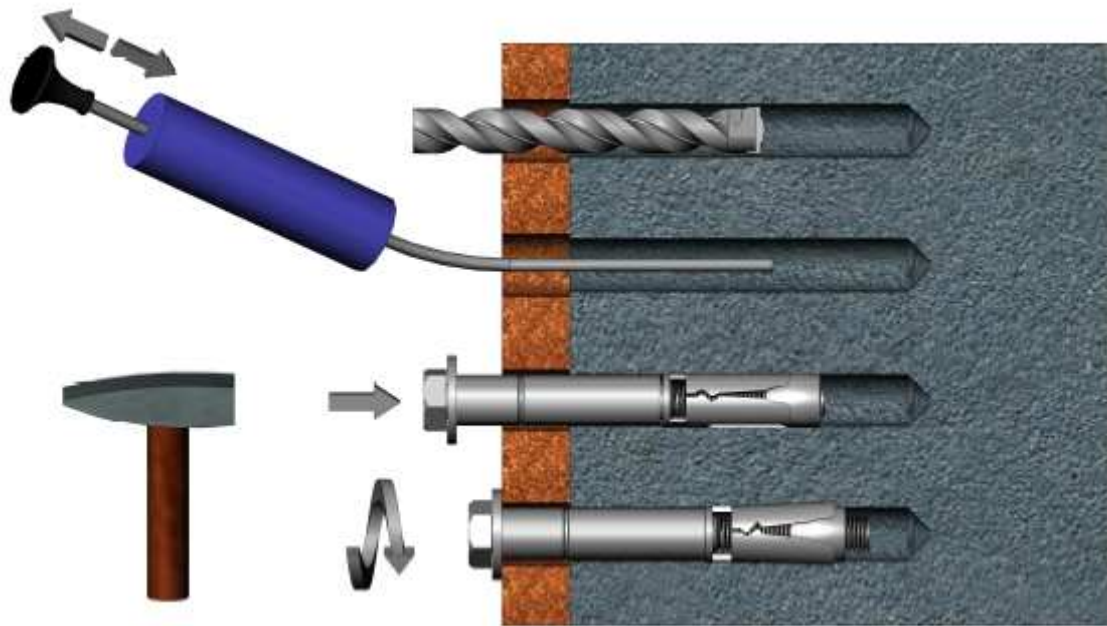

**RAWL SafetyPlus**

Installation instruction for RAWL SafetyPlus anchor type R-SPL

**Annex 4**  
of European  
Technical Approval  
ETA-11/0126



<p><b>RAWL SafetyPlus</b></p>	<p><b>Annex 5</b> of European Technical Approval ETA-11/0126</p>
<p>Installation instruction for RAWL SafetyPlus anchor type R-SPL-C</p>	

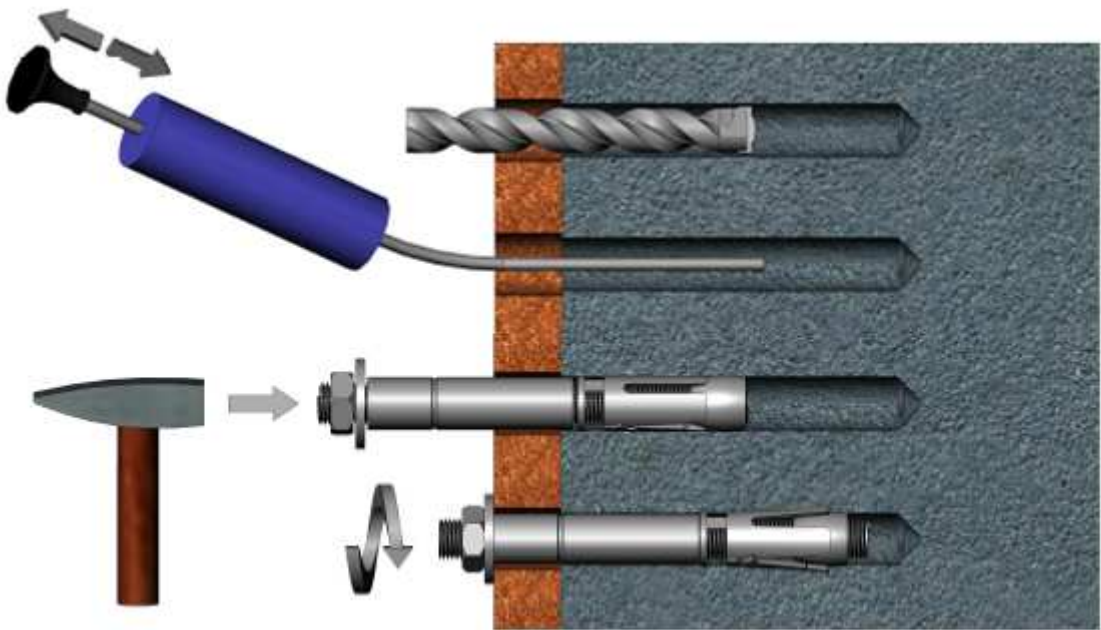

<p><b>RAWL SafetyPlus</b></p>	<p><b>Annex 6</b></p>
<p>Installation instruction for RAWL SafetyPlus anchor type R-SPL-BP</p>	<p>of European Technical Approval ETA-11/0126</p>

**Table 1: RAWL SafetyPlus anchor type R-SPL, dimensions**

Type of anchor				d [mm]	dc [mm]	L [mm]	SW [mm]
Size	Marking	M x L	t <sub>fix</sub> <sup>(1)</sup> [mm]				
M8	R-SPL-08090/15	M8 x 90	15	8	12	90	13
	R-SPL-08110/40	M8 x110	40			110	
M10	R-SPL-10105/20	M10 x 105	20	10	15	105	17
	R-SPL-10120/40	M10 x 120	40			120	
	R-SPL-10140/60	M10 x 140	60			140	
M12	R-SPL-12120/25	M12 x 120	25	12	18	120	19
	R-SPL-12150/50	M12 x 150	50			150	
M16	R-SPL-16145/25	M16 x 145	25	16	24	145	24
	R-SPL-16170/50	M16 x 170	50			170	
M20	R-SPL-20175/30	M20 x 175	30	20	28	175	30

<sup>1)</sup> – thickness of the fixed element

**Table 2: RAWL SafetyPlus anchor type R-SPL-C, dimensions**

Type of anchor				d [mm]	dc [mm]	L [mm]	HEX [mm]
Size	Marking	M x L	t <sub>fix</sub> <sup>(1)</sup> [mm]				
M8	R-SPL-C-08090/20	M8x90	20	8	12	90	6
M10	R-SPL-C-10105/25	M10 x 105	25	10	15	105	8
M12	R-SPL-C-10125/30	M12 x 125	30	12	18	125	10
M16	R-SPL-C-16145/30	M16 x 145	30	16	24	145	12

<sup>1)</sup> – thickness of the fixed element

<b>RAWL SafetyPlus</b>	<b>Annex 7</b> of European Technical Approval ETA-11/0126
Dimensions	

**Table 3: RAWL SafetyPlus anchor type R-SPL-BP, dimensions**

Type of anchor				d [mm]	dc [mm]	L [mm]	SW [mm]
Size	Marking	M x L	t <sub>fix</sub> <sup>1)</sup> [mm]				
M8	R-SPL-BP-08095/15	M8 x 95	15	8	12	95	13
M10	R-SPL-BP-10110/20	M10 x 110	20	10	15	110	17
M12	R-SPL-BP-12135/25	M12 x 135	25	12	18	135	19
	R-SPL-BP-12160/50	M12 x 160	50			160	
M16	R-SPL-BP-16160/25	M16 x 160	25	16	24	160	24
	R-SPL-BP-16185/50	M16 x 185	50			185	
M20	R-SPL-BP-20190/30	M20 x 190	30	20	28	190	30

<sup>1)</sup> – thickness of the fixed element

**Table 4: Materials**

Part	Designation	Material	Protection
1	Hexagonal screw	Carbon steel class 8.8 EN ISO 898-1	Zinc plated ≥ 5µm EN ISO 4042
2	Countersunk screw	Carbon steel class 8.8 EN ISO 898-1	Zinc plated ≥ 5µm EN ISO 4042
3	Threaded bolt	Carbon steel class 8.8 EN ISO 898-1	Zinc plated ≥ 5µm EN ISO 4042
4	Conical nut	Carbon steel EN 10263-2 (M8 ÷ M12) EN 10087 (M16 ÷ M20)	Zinc plated ≥ 5µm EN ISO 4042
5	Expansion sleeve	Carbon steel EN 10139	Zinc plated ≥ 5µm EN ISO 4042
6	Spacer sleeve	Carbon steel	Zinc plated ≥ 5µm EN ISO 4042
7	Hexagonal nut	Carbon steel	Zinc plated ≥ 5µm EN ISO 4042
8	Washer	Carbon steel	Zinc plated ≥ 5µm EN ISO 4042

<b>RAWL SafetyPlus</b>	<b>Annex 8</b> of European Technical Approval ETA-11/0126
Dimensions, materials	

**Table 5: Installation parameters**

Anchor size		M8	M10	M12	M16	M20
Effective anchorage depth	$h_{ef}$ [mm]	60	70	80	100	125
Nominal drill hole diameter	$d_o =$ [mm]	12	15	18	24	28
Depth of drill hole to deepest point	$h_1 \geq$ [mm]	85	95	105	130	160
Diameter of clearance hole in the fixture	$d_f \leq$ [mm]	14	17	20	26	30
Installation torque moment	$T_{inst} =$ [Nm]	25	50	80	180	275
Minimum thickness of member	$h_{min}$ [mm]	100	105	120	150	187,5
Minimum spacing	$s_{min}$ [mm]	60	70	80	100	125
	for $c \geq$ [mm]	90	105	120	150	187,5
Minimum edge distance	$c_{min}$ [mm]	90	105	120	150	185,5
	for $s \geq$ [mm]	180	210	240	300	375

**RAWL SafetyPlus**

Installation characteristics, minimum thickness of base material, edge distance and spacing

**Annex 9**  
 of European  
 Technical Approval  
 ETA-11/0126



**Table 6: Design method A, characteristic values for tension loads**

Anchor size		M8	M10	M12	M16	M20
<b>Steel failure</b>						
Characteristic resistance	$N_{Rk,s}$ [kN]	29,3	46,4	57,4	125,6	196,0
Partial safety factor	$\gamma_{Ms}^{1)}$	1,5				
<b>Pull-out failure</b>						
Characteristic resistance in non-cracked concrete C20/25 – C 50/60	$N_{Rk,p}$ [kN]	9	12	16	35	40
Partial safety factor	$\gamma_{Mp}^{1)}$	2,1 <sup>2)</sup>				
<b>Concrete cone failure</b>						
Effective anchorage depth	$h_{ef}$ [mm]	60	70	80	100	125
Spacing	$s_{cr,N}$ [mm]	180	210	240	300	375
Edge distance	$c_{cr,N}$ [mm]	90	105	120	150	188
<b>Splitting failure</b>						
Spacing	$s_{cr,sp}$ [mm]	180	210	240	300	375
Edge distance	$c_{cr,sp}$ [mm]	90	105	120	150	188
Partial safety factor	$\gamma_{Msc}^{1)}$	2,1				

<sup>1)</sup> – in absence of other national regulations

<sup>2)</sup> – the partial safety factor  $\gamma_2 = 1,4$  included

**Table 7: Displacements under tension loads**

Anchor size		M8	M10	M12	M16	M20
Tension load	N [kN]	3,06	4,08	6,80	11,90	13,61
Displacement	$\delta_{NO}$ [mm]	0,08	0,27	0,11	0,15	0,36
	$\delta_{N\infty}$ [mm]	1,00	1,00	1,00	1,00	1,00

**RAWL SafetyPlus**

Design method A, characteristic values  
for tension loads, displacements

**Annex 10**  
of European  
Technical Approval  
ETA-11/0126

**Table 8: Design method A, characteristic values for shear loads**

Anchor size	M8	M10	M12	M16	M20
<b>Steel failure without lever arm</b>					
Characteristic resistance $V_{Rk,s}$ [kN]	19,20	30,00	43,20	77,60	73,68
Partial safety factor $\gamma_{Ms}^{(1)}$	1,25				
<b>Steel failure with lever arm</b>					
Characteristic bending resistance $M_{Rk,s}^0$ [Nm]	45,04	87,97	152,01	365,97	728,54
Partial safety factor $\gamma_{Ms}^{(1)}$	1,25				
<b>Concrete pryout failure</b>					
Factor in equation (5.6) of ETAG 001 Annex C, 5.2.3.3	2,0				
Partial safety factor $\gamma_{Mcp}^{(1)}$	2,1 <sup>2)</sup>				
<b>Concrete edge failure</b>					
Effective length of anchor under shear loading $l_f$ [mm]	60	70	80	100	125
Effective diameter of anchor $d_{nom}$ [mm]	8	10	12	16	20
Partial safety factor $\gamma_{Mc}^{(1)}$	2,1				

<sup>1)</sup> – in absence of other national regulations

<sup>2)</sup> – the partial safety factor  $\gamma_2 = 1,0$  is included

**Table 9: Displacements under tension loads**

Anchor size	M8	M10	M12	M16	M20	
Shear load $V$ [kN]	6,53	10,20	14,69	26,39	25,06	
Displacement	$\delta_{v0}$ [mm]	1,91	0,99	2,07	2,44	2,81
	$\delta_{v\infty}$ [mm]	2,86	1,49	3,11	3,66	4,21

**RAWL SafetyPlus**

Design method A, characteristic values  
for shear loads, displacements

**Annex 11**  
of European  
Technical Approval  
ETA-11/0126